



# FoodSaver®

VACUUM SEALING SYSTEM



EN USER INSTRUCTIONS

[www.foodsaver.co.uk](http://www.foodsaver.co.uk)

MODEL  
FFS002 / FFS004 / FFS012

**FIG. 1**

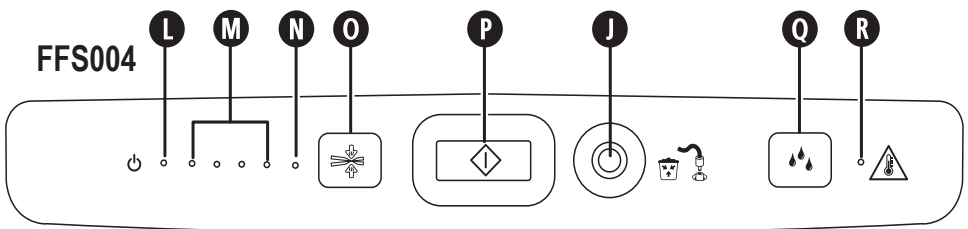
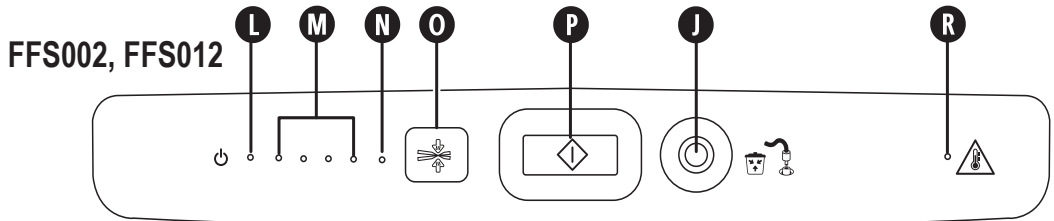
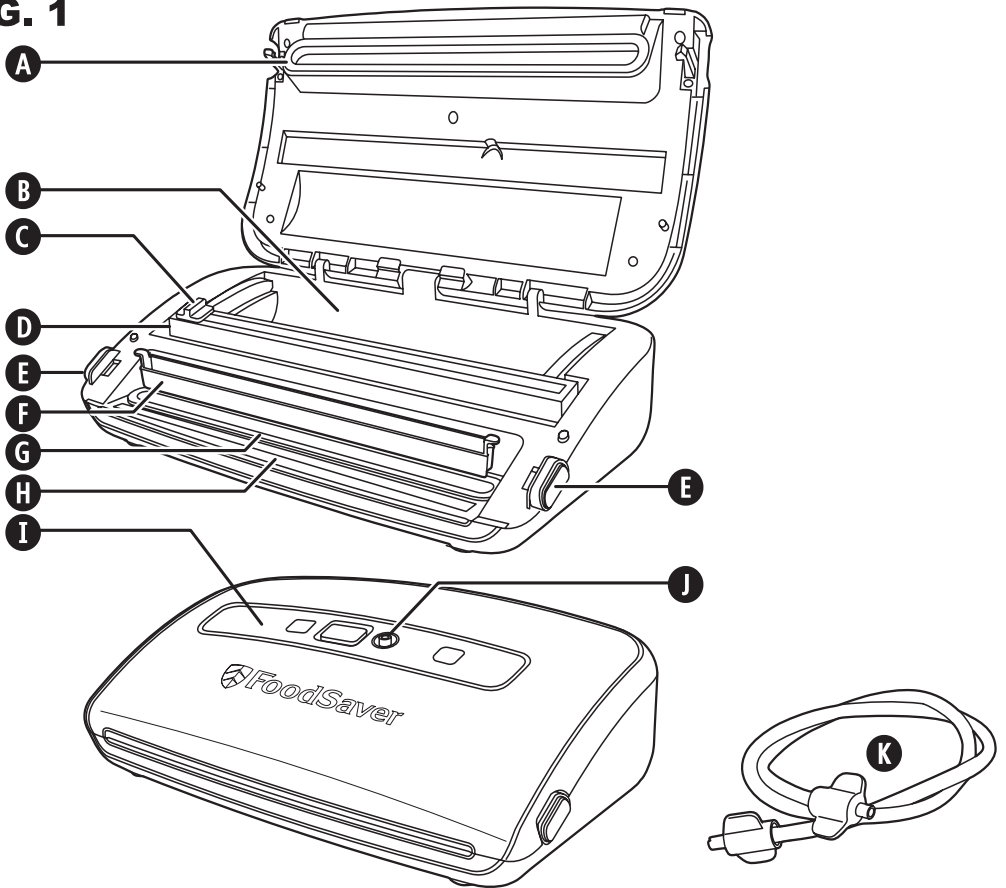

**FIG. 2**

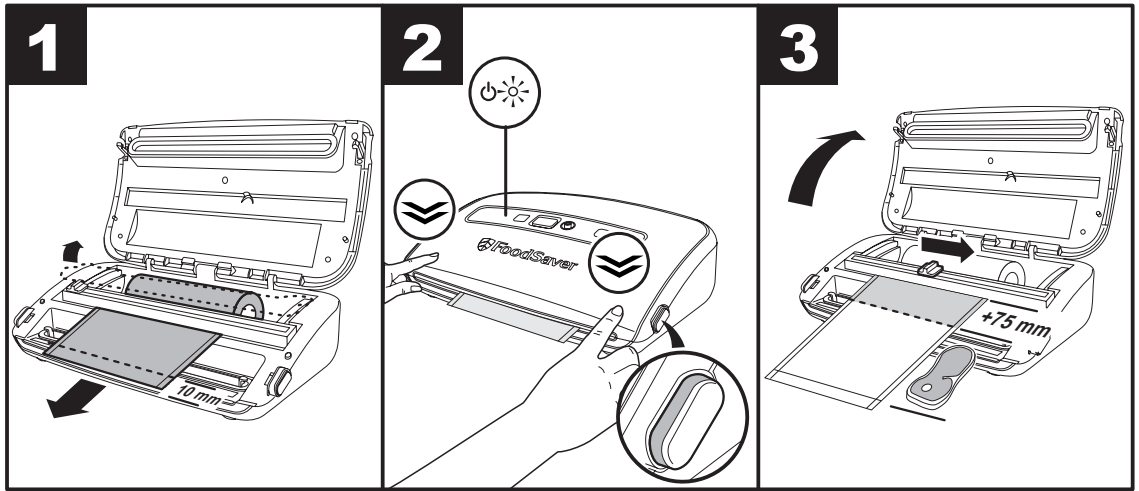

**FIG. 3**

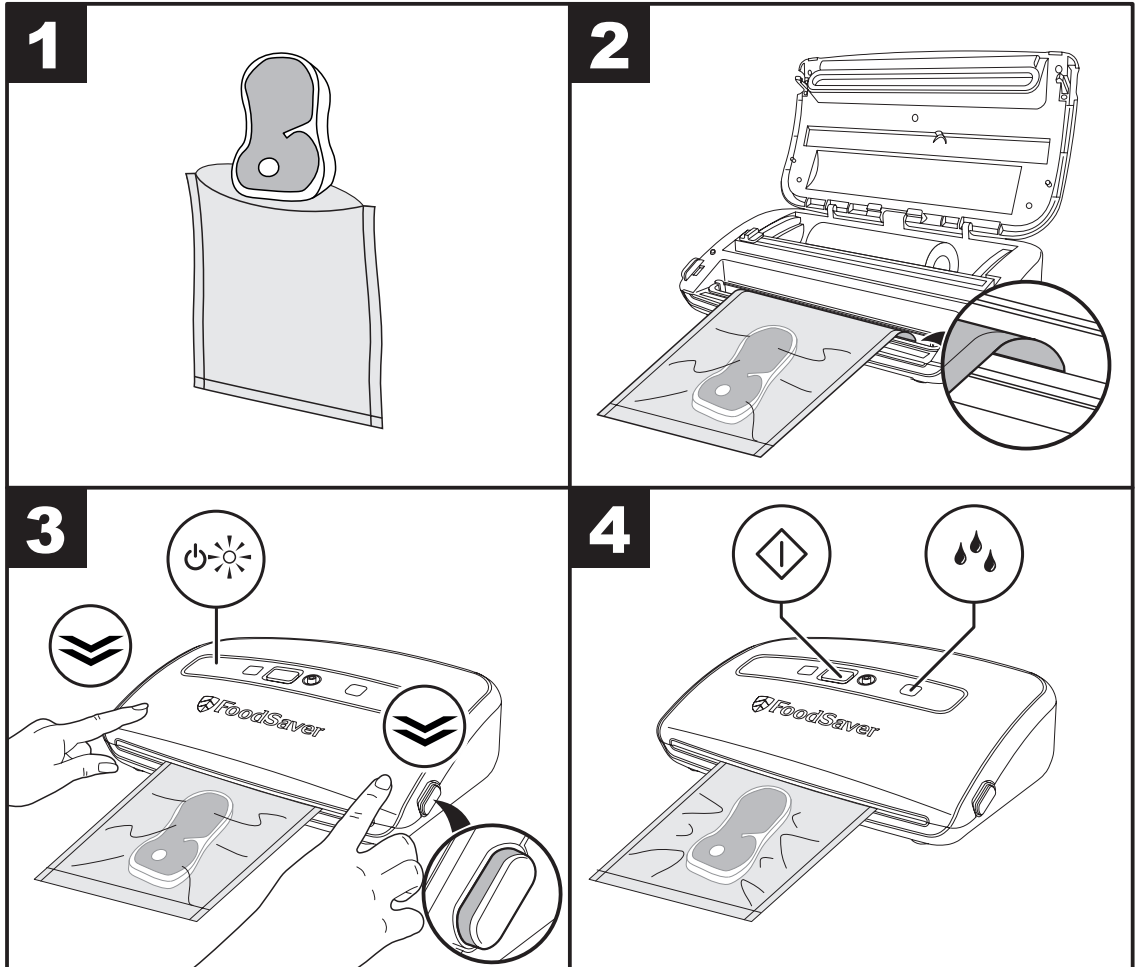

## Important Safeguards

---

This appliance can be used by children aged from 8 years and above and persons with reduced physical, sensory or mental capabilities or lack of experience and knowledge if they have been given supervision or instruction concerning use of the appliance in a safe way and understand the hazards involved. Children shall not play with the appliance. Cleaning and user maintenance shall not be made by children without supervision.

If the supply cord is damaged, it must be replaced by the manufacturer, or its service agent or a similarly qualified person in order to avoid a hazard.

- Always use the appliance on a stable, secure, dry and level surface.
- **CAUTION: THIS SEALER IS NOT FOR COMMERCIAL USE.** Never use this appliance for anything other than its intended use. This appliance is for household use only. Do not use this appliance outdoors.
- Never immerse the appliance or power cord and plug in water or any other liquid.
- Do not use the appliance if it has been dropped or if there are any visible signs of damage.
- Ensure the appliance is switched off and unplugged from the supply socket after use, before cleaning.
- To disconnect, unplug the power cord from the electrical outlet. Do not disconnect by pulling on the cord.
- Do not use an extension cord with the appliance.
- Use only accessories or attachments recommended by the manufacturer.
- When reheating foods in FoodSaver® Bags make sure to place them in water at a low simmering temperature below 75°C (170°F).
- **FOODS INSIDE BAG CAN BE DEFROSTED BUT NOT REHEATED IN A MICROWAVE OVEN.** When defrosting foods in the microwave in FoodSaver® Bags make sure not to exceed maximum power of 180 watts, maximum time of 2 minutes and maximum temperature of 70°C (158°F).

### SAVE THESE INSTRUCTIONS

## FoodSaver® Vacuum Sealing System

---

### Why Vacuum Package?

Exposure to air causes food to lose nutrition and flavour, and also causes freezer burn and enables many bacteria, mould and yeast to grow. The FoodSaver® vacuum packaging system removes air and seals in flavour and quality. With a full line of FoodSaver® bags, and canisters to expand your options, you can now enjoy the benefits of a scientifically proven food storage method that keeps food fresh up to five times longer.

### The FoodSaver® System Saves Time and Money.

- **Spend less money.** With the FoodSaver® system, you can buy in bulk or buy on sale and vacuum package your food in desired portions without wasting food.
- **Save more time.** Cook ahead for the week, preparing meals and saving them in FoodSaver® bags.
- **Marinate in minutes.** Vacuum packaging opens up the pores of food so you can get that great marinated flavour in just 20 minutes instead of overnight.
- **Make entertaining easy.** Make your signature dish and holiday treats in advance so you can spend quality time with your guests.
- **Enjoy seasonal or specialty foods.** Keep highly perishable or infrequently used items fresh longer.
- **Control portions for dieting.** Vacuum package sensible portions and write calories and/or fat grams on the bag.
- **Protect non-food items.** Keep camping and boating supplies dry and organised for outings. Protect polished silver from tarnishing by minimising exposure to air.

## FoodSaver® Accessories

---

Get the most out of your FoodSaver® appliance with easy-to-use FoodSaver® bags, canisters and accessories.

### FoodSaver® Bags and Rolls

FoodSaver® bags and rolls feature special channels that enable the efficient removal of air. The multi-ply construction makes them an especially effective barrier to oxygen and moisture and helps to prevent freezer burn. FoodSaver® bags and rolls come in a variety of sizes.

### FoodSaver® Canisters

FoodSaver® canisters are simple to use and ideal for vacuum packaging delicate items such as muffins and other baked goods, liquids and dry goods.

### FoodSaver® Bottle Stopper

Use FoodSaver® bottle stoppers to vacuum package wine, non-carbonated liquids and oils. This will extend the life of the liquid and preserve the flavour. Don't use the bottle stopper on plastic bottles.

### FoodSaver® Quick Marinator

The quick marinator infuses food with flavour in minutes instead of hours using vacuum power to penetrate marinades deep into the food.

### Ordering

To order FoodSaver® bags, rolls and accessories please visit [www.foodsaver.co.uk](http://www.foodsaver.co.uk).

## Parts

See figure 1

- A** Upper gasket
- B** Roll storage
- C** Roll cutter
- D** Roll cutter bar
- E** Lid latch
- F** Removable drip tray
- G** Lower gasket
- H** Sealing strip
- I** Control panel
- J** Accessory port
- K** Accessory hose
- L** Power light
- M** Progress lights
- N** Sealing progress light
- O** Seal Only button
- P** Vacuum and Seal button
- Q** Moist Food button (FFS004 only)
- R** Overheat warning light

## Making a bag from a FoodSaver® roll

You can make your own custom sized bags from a FoodSaver® roll. Referring to Fig. 2:

1. Plug your vacuum sealer in to a mains supply socket. Press both latches **E** and open the lid. If you haven't already done so, place the FoodSaver® roll into the storage area **B** then lift up the roll cutter bar **D** and feed the roll end under the bar. Pull the roll end out until about 10mm of the roll overlaps the sealing strip **H**.
2. Close the lid all the way until the latches **E** pop out. When correctly closed, a green band will appear around the latch and the green power light **L** will come on. Press the Seal Only button **O**. When the red sealing progress light **N** goes out, press both latches and open the lid. The end of the roll will now have been sealed.
3. Pull the roll out to the required length for the item being packaged. Add an extra 75mm to allow the bag to be sealed then slide the roll cutter **C** across to cut the roll.

## Using Your Vacuum Sealer

Referring to Fig. 3:

1. Place the item to be packaged into the bag. You can use a ready made FoodSaver® bag or make your own from a FoodSaver® roll.
2. Place the open end of the bag into the slot of the drip tray **F**.
3. Close and latch the lid. When correctly closed, a green band will appear around the latch and the green power light **L** will come on.
4. Press the Vacuum and Seal button **P**.
5. Your vacuum packager will start to remove the air from the bag and then seal it. When the progress lights **M** have stopped and the red sealing progress light **N** has gone out, the process is complete.

### Packaging moist foods (FFS004 only)

If you are packaging foods that are moist or are very juicy, press the Moist Food button **Q** BEFORE pressing the Vacuum and Seal button.

### Sealing a bag without removing any air

To seal a bag without extracting the air from it press the Seal Only button **O**. You can seal the types of bag that are used to package snacks such as potato crisps, tortilla chips, etc.

### Sealing delicate items

Some items such as pastries, bread, biscuits, etc. can be crushed when sealing. To prevent this, use the Seal Only button **O** as follows:

1. Follow steps 1, 2, 3 and 4 of *Using Your Vacuum Sealer*.
2. Press the Seal Only button **O** before crushing occurs. This will immediately stop more air from being extracted and then seal the bag.

### Using FoodSaver® accessories

1. Insert one end of the accessory hose **K** to the accessory port **J**. Insert the other end of the hose into the port on the accessory. Follow any specific instructions that come with the FoodSaver accessory.
2. Follow steps 3 and 4 of *Using Your Vacuum Sealer*.

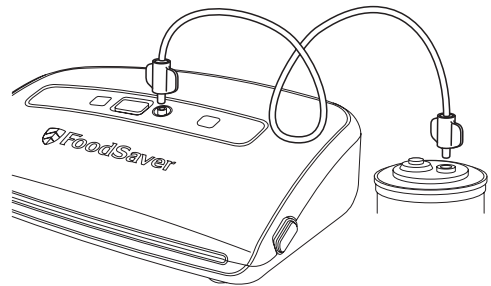

# Storage Guide, Hints and Tips

## Vacuum Packaging and Food Safety

The vacuum packaging process extends the life of foods by removing most of the air from the sealed container, thereby reducing oxidation, which affects nutritional value, flavour and overall quality. Removing air can also inhibit growth of microorganisms, which can cause problems under certain conditions.

To preserve foods safely, it is critical that you maintain low temperatures. You can significantly reduce the growth of microorganisms at temperatures of 4°C or below.

Freezing at -17°C does not kill microorganisms, but stops them from growing. For long-term storage, always freeze perishable foods that have been vacuum packaged, and keep refrigerated after thawing.

It is important to note that vacuum packaging is NOT a substitute for canning and it cannot reverse the deterioration of foods. It can only slow down the changes in quality. It is difficult to predict how long foods will retain their top-quality flavour, appearance or texture because it depends on age and condition of the food on the day it was vacuumed packaged.

<b>Foods</b>	<b>Storage Life</b>
Beef, Pork, Lamb, Poultry	2-3 years
Minced Meat	1 year
Fish	2 years
Hard Cheeses (Cheddar, Parmesan, Edam, Gouda, etc.)	4-8 months
Asparagus, Broccoli, Carrot, Cauliflower, Cabbage, Brussels Sprouts, Green Beans, Peas, Corn, etc.	2-3 years
Lettuce, Spinach, etc.	2 weeks
Apricots, Plums, Peaches, Nectarines, etc	1-3 years
Soft Berries (Raspberries, Blackberries, Strawberries, etc)	1 week
Hard Berries (Blueberries, Cranberries, etc.)	2 weeks
Bread, Bagels, Pastries	1-3 years
Nuts and Seeds	2 years
Coffee Beans	1 year
Ground Coffee	5-6 months
Powdered Goods (Sugar, Flour, etc.)	1-2 years
Sauces, Soups, Stews, etc.	1-2 years
Dried Goods (Beans, Pasta, Rice, Grains, etc.)	1-2 years
Potato Crisps, Biscuits, Crackers, etc.	3-6 weeks

**IMPORTANT:** Vacuum packaging is NOT a substitute for refrigeration or freezing. Any perishable foods that require refrigeration must still be refrigerated or frozen after vacuum packaging. To avoid possible illness, do not reuse bags after storing raw meats, raw fish or greasy foods. Do not reuse bags that have been microwaved or simmered.

### Thawing and Reheating Vacuum Packaged Foods

FOODS INSIDE BAG CAN BE DEFROSTED BUT NOT REHEATED IN A MICROWAVE OVEN.

**Defrosting** - Always thaw foods in a refrigerator or a microwave oven — do not thaw perishable foods at room temperature. Make sure to cut off the corner of the bag before placing it in the microwave. We recommend that you place the bag on a microwave-safe dish to avoid liquids from spilling out.

**Reheating** - To reheat foods in a microwave oven, remove it from bag and place it on a microwave-safe dish.

You can also reheat foods in FoodSaver® bags by placing them in water at a low simmering temperature below 75°C (170°F). Make sure the food is fully heated throughout.

Where to Store	Remarks
Freezer	Pre-freeze moist foods before vacuum packaging. Alternatively, place a folded paper towel between the food and the end of the bag to absorb excess liquid. Remember to leave 75mm of space after the towel to allow room for the seal to be created. <b>Note:</b> Beef may appear darker after vacuum packaging due to the removal of oxygen. This is not an indication of spoilage.
Freezer	
Freezer	
Refrigerator	To keep cheese fresh vacuum package it after each use. Make the bags extra long to allow 25mm for each new seal required. NEVER vacuum package soft cheeses.
Always store in the freezer	Blanch vegetables until they are cooked but still crisp before packaging. Freeze before packaging. Separate during freezing to avoid vegetables sticking together when they are packaged. NEVER vacuum package fresh mushrooms.
Refrigerator	Wash then dry. For best results, package using a FoodSaver® canister.
Freezer	Pre-freeze soft fruits and berries before packaging. Separate during freezing to avoid fruits sticking together when they are packaged.
Refrigerator	
Refrigerator	
Freezer	We recommend using a FoodSaver® canister to avoid crushing. Alternatively, pre-freeze until solid.
Pantry	To prevent food particles from being drawn into the vacuum pump, place a coffee filter or paper towel at top of the bag or canister before vacuum packaging. You can also place the food in its original bag inside a FoodSaver® bag.
Pantry	
Pantry	
Pantry	
Freezer	Pre-freeze in a suitable container until solid. Remove frozen liquid and vacuum package in a FoodSaver® Bag.
Pantry	For best results, use a FoodSaver® canister for crushable items like crackers.
Pantry	

## Care and Cleaning

Never immerse the unit or power cord and plug in water or any other liquid. Always unplug the unit before cleaning.

Wipe over the body of the appliance with a soft, dry cloth.

Remove and empty the drip tray **F** after each use. Wash it in warm soapy water or place it in the top rack of a dishwasher. Dry thoroughly before refitting.

Check the upper gasket **A**, lower gasket **G** and around the drip tray to make sure they are free from food debris. Wipe the gaskets with a warm soapy cloth if needed. The gaskets may be removed for cleaning. Clean them with warm, soapy water. Dry thoroughly then carefully refit.

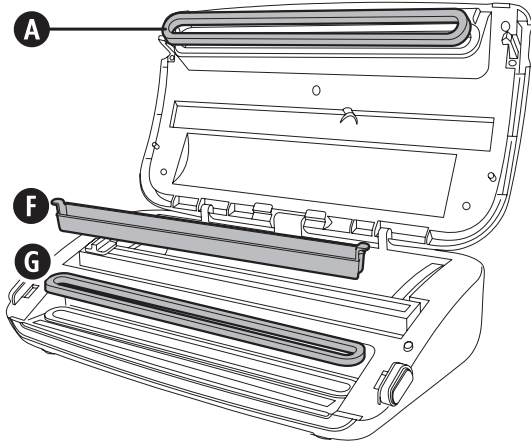

To keep your FoodSaver® appliance operating effectively, we recommend that you replace the gaskets every year.

To order replacements, please visit [www.foodsaver.co.uk](http://www.foodsaver.co.uk) or contact FoodSaver® Brand Customer Service on 0800 525 089.

## Storage

Close the lid to the first 'click' until the latches catch but don't pop out and reveal the green band. This is enough to secure the lid but avoids compressing the gaskets (which may cause incorrect functioning of the unit).

Wrap the cable around the cleats underneath the unit. The unit can be stored stood upright as shown.

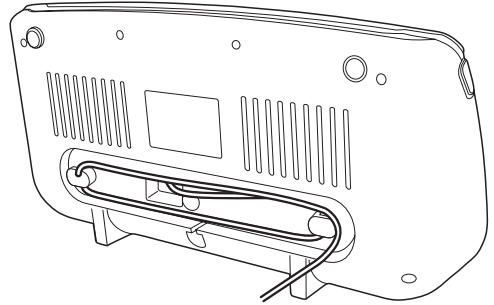

# Troubleshooting

Problem	Solution
Overheat warning light  comes on	The unit has overheated. Wait until the overheat warning light goes out before using.
Pump operates for more than 2 minutes without air being removed.	<p>Make sure the open end of the bag is inserted into the drip tray.</p> <p>Check to make sure both gaskets are fitted properly.</p> <p>Check to make sure that at least one end of the bag is sealed.</p> <p>Open the unit and check to make sure that there are no foreign objects, dirt or debris on the upper or lower gaskets.</p> <p>Make sure there is enough room at the top of the bag (75 mm) so it will fit into the drip tray with lid closed and latched.</p> <p>Make sure the accessory hose is not attached.</p> <p>Make sure the lid is fully closed (the green band is showing around the latch and the green power light is on).</p>
Bag is not sealing properly.	<p>There is too much liquid in the bag. Freeze the bag contents before vacuuming.</p> <p>To prevent wrinkles in the seal, gently stretch the bag flat while inserting the bag into the drip tray and continue to hold bag until vacuum pump starts.</p> <p>Create a second seal above the first seal on the bag to ensure a proper seal when sealing moist foods.</p>
Nothing happens when latch is closed and Vacuum and Seal button or Seal Only button is pressed.	Make sure the lid is fully closed (the green band is showing around the latch and the green power light is on).

## Guarantee

Please keep your receipt as this will be required for any claims under this guarantee.

This appliance is guaranteed for 2 years after your purchase as described in this document.

During this guaranteed period, if in the unlikely event the appliance no longer functions due to a design or manufacturing fault, please take it back to the place of purchase, with your till receipt and a copy of this guarantee.

The rights and benefits under this guarantee are additional to your statutory rights, which are not affected by this guarantee. Only Jarden Consumer Solutions (Europe) Limited ("JCS (Europe)") has the right to change these terms.

JCS (Europe) undertakes within the guarantee period to repair or replace the appliance, or any part of appliance found to be not working properly free of charge provided that:

- you promptly notify the place of purchase or JCS (Europe) of the problem; and
- the appliance has not been altered in any way or subjected to damage, misuse, abuse, repair or alteration by a person other than a person authorised by JCS (Europe).

Faults that occur through, improper use, damage, abuse, use with incorrect voltage, acts of nature, events beyond the control of JCS (Europe), repair or alteration by a person other than a person authorised by JCS (Europe) or failure to follow instructions for use are not covered by this guarantee. Additionally, normal wear and tear, including, but not limited to, minor discoloration and scratches are not covered by this guarantee.

The rights under this guarantee shall only apply to the original purchaser and shall not extend to commercial or communal use.

If your appliance includes a country-specific guarantee or warranty insert please refer to the terms and conditions of such guarantee or warranty in place of this guarantee or contact your local authorized dealer for more information.

Waste electrical products should not be disposed of with Household waste. Please recycle where facilities exist. E-mail us at [enquiriesEurope@jardencs.com](mailto:enquiriesEurope@jardencs.com) for further recycling and WEEE information.

Jarden Consumer Solutions (Europe) Limited  
5400 Lakeside  
Cheadle Royal Business Park  
Cheadle  
SK8 3GQ  
United Kingdom



## Installation of a plug

If the plug is not suitable for the socket outlets in your home, it can be removed and replaced by a plug of the correct type. If you remove the plug it must not be connected to a 13 amp socket and the plug must be disposed of immediately.

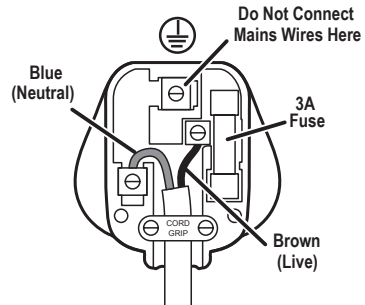

NOTE: If the terminals in the plug are not marked or if you are unsure or in doubt about the installation of the plug please contact a qualified electrician.

If a 13A 3-pin plug is fitted, it must be an ASTA approved plug, conforming to BS1363 standard. Replacement fuses must be BSI or ASTA BS1362 approved.

The wires in the mains lead are coloured as such:

- BROWN - LIVE
- BLUE - NEUTRAL

Please note that the colour of these mains wires may not correspond with the colour markings that identify the terminals in your plug.

The BROWN coloured wire must be connected to the terminal, which is marked with the letter "L" or is coloured RED.

The BLUE coloured wire must be connected to the terminal, which is marked with the letter "N" or is coloured BLACK.

DO NOT CONNECT either of these wires to the earth terminal in the plug. The earth terminal plug is marked with the letter "E", or with the earth symbol  $\perp$ , or coloured GREEN, or GREEN and YELLOW.





**Jarden Consumer Solutions (Europe) Limited**  
Cheadle Royal Business Park, Cheadle, SK8 3GQ, United Kingdom  
e-mail: [enquiriesEurope@jardencs.com](mailto:enquiriesEurope@jardencs.com)  
Tel: 0161 621 6900



For Customer Service details, please see the website.

[www.foodsaver.co.uk](http://www.foodsaver.co.uk)

© 2016 Jarden Consumer Solutions (Europe) Limited.

All rights reserved. Imported and distributed by Jarden Consumer Solutions (Europe) Limited, 5400 Lakeside, Cheadle Royal Business Park, Cheadle, SK8 3GQ, United Kingdom.  
Jarden Consumer Solutions (Europe) Limited is a subsidiary of Newell Brands Inc. (NYSE: NWL).

The product supplied may differ slightly from the one illustrated due to continuing product development.  
Printed in China