



FoodSaver®



FRESH FOOD PRESERVATION SYSTEM



EN USER INSTRUCTIONS

MODEL
FFS010, FFS011

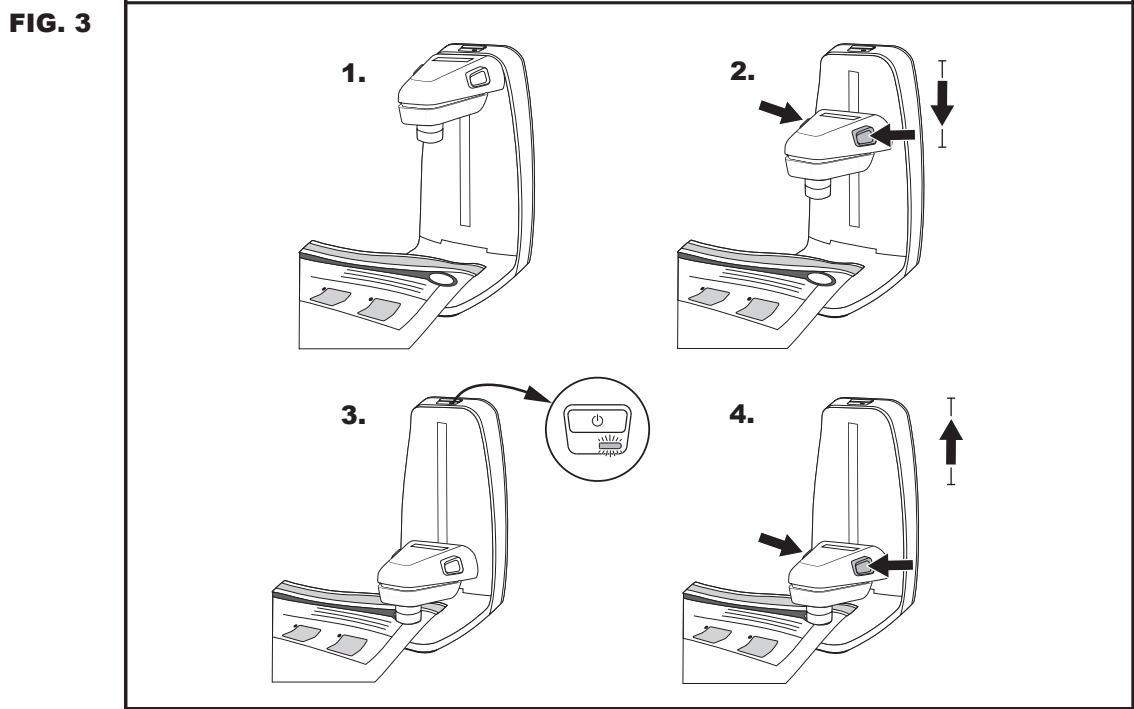
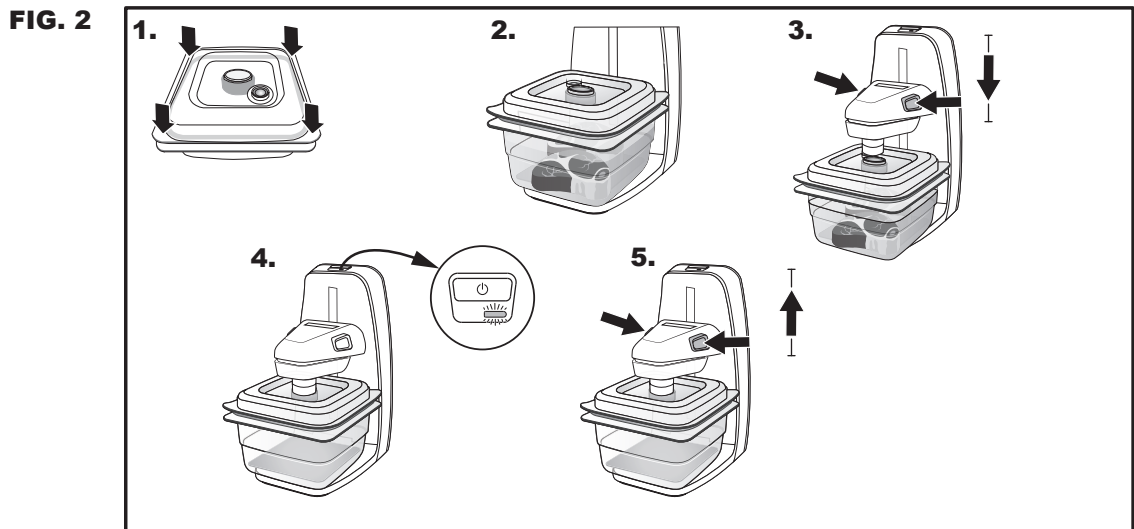
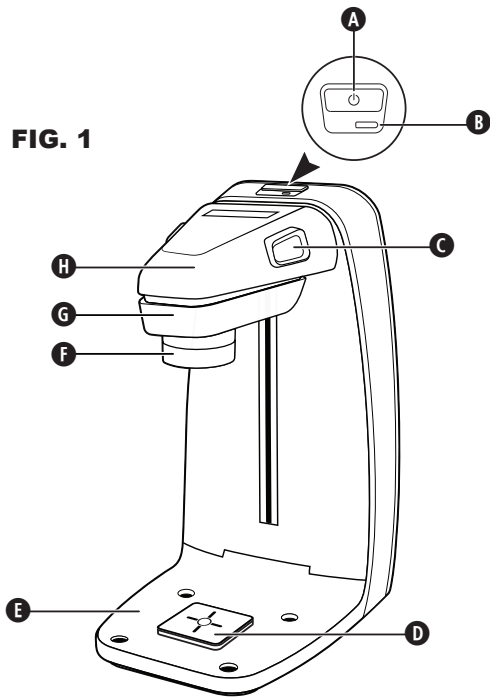

Important Safeguards

This appliance can be used by children aged from 8 years and above and persons with reduced physical, sensory or mental capabilities or lack of experience and knowledge if they have been given supervision or instruction concerning use of the appliance in a safe way and understand the hazards involved. Children shall not play with the appliance. Cleaning and user maintenance shall not be made by children without supervision.

If the supply cord is damaged, it must be replaced by the manufacturer, or its service agent or a similarly qualified person in order to avoid a hazard.

- Always use the appliance on a stable, secure, dry and level surface.
- CAUTION: THIS APPLIANCE IS NOT FOR COMMERCIAL USE. Never use this appliance for anything other than its intended use. This appliance is for household use only. Do not use this appliance outdoors.
- Never immerse the appliance or power cord and plug in water or any other liquid.
- Do not use the appliance if it has been dropped or if there are any visible signs of damage.
- Ensure the appliance is switched off and unplugged from the supply socket after use, before cleaning.
- To disconnect, unplug the power cord from the electrical outlet. Do not disconnect by pulling on the cord.
- Do not use an extension cord with the appliance.
- Use only accessories or attachments recommended by the manufacturer.

SAVE THESE INSTRUCTIONS

FoodSaver® Vacuum Sealing System

Why Vacuum Package?

Exposure to air causes food to lose nutrition and flavour, and also enables many types of bacteria, mould and yeast to grow. The FoodSaver® vacuum packaging system removes air and seals in flavour and quality. You can now enjoy the benefits of a scientifically proven food storage method that keeps food fresh up to five times longer.

The FoodSaver® System Saves Time and Money

- **Spend less money.** With the FoodSaver® system, you can buy in bulk or buy on sale and vacuum package your food in desired portions without wasting food.
- **Save more time.** Cook ahead for the week, preparing meals and saving them in FoodSaver® bags.
- **Marinate in minutes.** Vacuum packaging opens up the pores of food so you can get that great marinated flavour in just 20 minutes instead of overnight.
- **Make entertaining easy.** Make your signature dish in advance so you can spend quality time with your guests.
- **Enjoy seasonal or specialty foods.** Keep highly perishable or infrequently used items fresh longer.
- **Control portions for dieting.** Vacuum package sensible portions and write the calories and fat content on the bag.
- **Protect non-food items.** Keep camping and boating supplies dry and organised for outings. Protect polished silver from tarnishing by minimizing exposure to air.

FoodSaver® Accessories

Get the most out of your FoodSaver® appliance with easy-to-use FoodSaver® containers and bags.

FoodSaver® Fresh Zipper Bags

FoodSaver® Zipper Bags feature special channels that enable the efficient removal of air. The multi-ply construction makes them an especially effective barrier to oxygen and moisture.

FoodSaver® Fresh Containers

FoodSaver® Fresh Containers are simple to use and ideal for vacuum packaging delicate items such as muffins and other baked goods, liquids and dry goods.

Ordering

To order FoodSaver® accessories please visit www.foodsaver.co.uk.

Parts

See Fig. 1:

- | | |
|------------------------------|----------------------|
| A Start button | E Base |
| B Ready light | F Vacuum port |
| C Release button (x2) | G Reservoir |
| D Platform | H Vacuum head |

Using your Fresh Food Preservation System

Vacuum Seal with FoodSaver® Fresh Containers

See Fig. 2:

1. Place the item to be vacuum sealed into the container. Fit the lid onto the container base. Press firmly on all corners to ensure that the lid is sealed.
2. Place the container onto the base using the platform as a guide.
3. Press both release buttons on the vacuum head to adjust its height. Guide the vacuum head onto the container valve until it clicks. The green ready light will come on.
Note: The green light will only come on if the vacuum head has made secure contact with the container valve.
4. Press the Start button to initiate the vacuum sealing process. The vacuum indicator on the container will dimple inwards early during the vacuum sealing process. Do not stop the process. The appliance will stop automatically when the container is fully vacuum sealed.
5. Press both release buttons on the vacuum head to lift it up then remove the sealed container.

You can marinate food quickly using FoodSaver® Fresh Containers. Place the food into the container, fully cover with your favourite marinade, and press the lid on firmly to seal.

You can then follow steps 2–5 of *Vacuum Seal with FoodSaver® Fresh Containers*. Leave the food vacuum sealed for 20 minutes to make sure that the marinade penetrates the food.

Vacuum Seal with FoodSaver® Fresh Zipper Bags

The FoodSaver® Fresh Zipper Bags should be used for fresh storage only (in the refrigerator or pantry) and not in the freezer. Do not use to vacuum seal liquids.

If vacuuming moist foods, ensure that the liquid does not reach the zipper bag valve and check and clean the appliance reservoir when needed.

See Fig. 3:

1. Place the item to be vacuum sealed into the bag. Place the bag onto the base using the platform as a guide and align the bag valve.
2. Press both release buttons on the vacuum head to adjust its height. Guide the vacuum head onto the bag valve until it clicks. The green ready light will come on.
Note: The green light will only come on if the vacuum head has made secure contact with the bag valve.
3. Press the Start button to initiate the vacuum sealing process. The appliance will stop automatically when the bag is fully vacuum sealed.
4. Press both release buttons on the vacuum head to lift it up then remove the sealed bag.

FoodSaver® Fresh Zipper Bag Tips

- Avoid overfilling; always leave space between the bag contents and the zipper. This allows room for the bag material to seal tightly against the food.
- Make sure to slide your fingers across the zipper to close the bag before placing it onto the appliance.
- When you are vacuum packaging items with sharp edges (dry spaghetti, silverware, etc.), protect the bag from punctures by wrapping items in soft cushioning material, such as paper towel.

Storage Guide, Hints and Tips

Vacuum Packaging and Food Safety

The vacuum packaging process extends the life of foods by removing most of the air from the sealed container, thereby reducing oxidation, which affects nutritional value, flavour and overall quality. Removing air can also inhibit growth of microorganisms, which can cause problems under certain conditions:

To preserve foods safely, it is critical that you maintain low temperatures. You can significantly reduce the growth of microorganisms at temperatures of 4°C or below.

Freezing at -17°C does not kill microorganisms, but stops them from growing. For long-term storage, always freeze perishable foods that have been vacuum packaged, and keep refrigerated after thawing. The FoodSaver® Fresh Zipper Bags should be used for fresh storage only (in the refrigerator or pantry) and not in the freezer.

Storage Guide, Hints and Tips (cont'd.)

It is important to note that vacuum packaging is NOT a substitute for canning and it cannot reverse the deterioration of foods. It can only slow down the changes in quality. It is difficult to predict how long foods will retain their top-quality flavour, appearance or texture because it depends on age and condition of the food on the day it was vacuum packaged.

IMPORTANT: Vacuum packaging is NOT a substitute for refrigeration or freezing. Any perishable foods that require refrigeration must still be refrigerated or frozen after vacuum packaging. To avoid possible illness, do not reuse bags after storing raw meats, raw fish or greasy foods.

Thawing and Reheating Vacuum Packaged Foods



Always thaw foods in a refrigerator or a microwave oven — do not thaw perishable foods at room temperature.

To reheat foods in a microwave in a FoodSaver® Fresh Container, release the vacuum valve and keep the lid on.

IMPORTANT: FoodSaver® Fresh Zipper Bags should never be used in microwave ovens to reheat foods or to thaw foods.

Preparation Guidelines

Meat



Beef may appear darker after vacuum sealing due to the removal of oxygen. This is not an indication of spoilage.

Hard Cheeses



To keep cheese fresh, vacuum seal it after each use. When you're ready to reseal the cheese, just place it back into the FoodSaver® Fresh Container or Fresh Zipper Bag and vacuum again.

IMPORTANT: Due to the risk of anaerobic bacteria, soft cheeses should never be vacuum sealed.

Vegetables



Vegetables must be blanched before vacuum sealing. This process stops the enzyme action that could lead to loss of flavour, colour and texture.

To blanch vegetables, place them in boiling water or in the microwave until they are cooked, but still crisp. Blanching times range from 1 to 2 minutes for leafy greens and peas; 3 to 4 minutes for snap peas, sliced courgette or broccoli; 5 minutes for carrots; and 7 to 11 minutes for corn on the cob.

After blanching, immerse vegetables in cold water to stop the cooking process. Finally, dry vegetables on a towel before vacuum sealing.

Note: Some foods (including broccoli, Brussels sprouts, cabbage, cauliflower, kale, turnips and bananas) naturally emit gases during storage. Therefore, after blanching, they must be stored in the freezer only.

When freezing vegetables, it is best to pre-freeze them for 1-2 hours or until solidly frozen. To freeze vegetables in individual servings, first place on a baking sheet and spread them out so they are not touching. This prevents them from freezing together in a block. When frozen, remove the vegetables from the baking sheet and vacuum seal vegetables in a FoodSaver® Fresh Container. After vacuum sealing, return the vegetables to the freezer.

IMPORTANT: Due to the risk of anaerobic bacteria, fresh mushrooms, onions and garlic should never be vacuum sealed.

Leafy Vegetables



First wash the vegetables, and then dry with a towel or salad spinner. After they are dried, put them in a FoodSaver® Fresh Container and vacuum seal as normal. Store in refrigerator.

Fruits



You can vacuum seal portions for baking, or in your favourite combinations for easy fruit salad all year round. If storing in the refrigerator, we recommend using a FoodSaver® Fresh Container.

Baked Goods



To vacuum seal soft or airy baked goods, we recommend using a FoodSaver® Fresh Container so they will hold their shape. To save time, make cookie dough, pie shells, whole pies, or mix dry ingredients in advance and vacuum seal for later use.

Coffee and Powdery Foods



To prevent food particles from being drawn into the vacuum pump, place a coffee filter or paper towel at the top of the bag or canister before vacuum sealing. You can also place the food in its original bag inside a FoodSaver® Fresh Zipper Bag, or use a FoodSaver® Fresh Container to vacuum seal.

Liquids



Wait for hot liquids to cool to room temperature before vacuum sealing in a FoodSaver® Fresh Container. Vacuum sealing hot liquids may result in loss of vacuum.

Care and Cleaning

Never immerse the appliance or power cord and plug in water or any other liquid. Always unplug the appliance before cleaning.

Wipe over the body of the appliance with a soft, dry cloth.

Slide out the reservoir after each use to clean it of moisture. To remove the reservoir, hold it with two fingers and pull down from the vacuum head. Wash in warm soapy water and allow to air dry thoroughly.

The gasket on the reservoir may also be removed for cleaning. Wash with warm soapy water and let dry thoroughly before re-fitting.

Check that the vacuum port is free from food debris. Wipe clean with a soft, dry cloth.

Storage

Make sure that the appliance is clean and store upright, on a flat, level surface, away from the edge and where it cannot be easily knocked over.

Troubleshooting

Problem	Solution
The appliance is not vacuuming air out of the FoodSaver® Fresh Zipper bag.	<ul style="list-style-type: none">• Make sure that the bag is firmly closed.• The air valve is not on a flat surface. Reposition the bag so that the air valve lies flat on the appliance platform with no food underneath.
Vacuum nozzle and air valve are not making contact.	<ul style="list-style-type: none">• Make sure that the vacuum nozzle is centred over the gray circle and placed flat on the air valve. Apply moderate pressure.
Air was removed from the bag but now air has re-entered.	<ul style="list-style-type: none">• Examine the bag's zip and valve. Food debris in the zip or valve may cause leakage and allow air to enter.• Sometimes moisture or food material along the seal edges of the zipper or beneath the valve prevents the bag from sealing properly. Wipe the inside of the bag around the zip and beneath valve and attempt to reseal.• If you are vacuum packaging sharp food items, the bag may have been punctured. Use a new bag if there is a hole. Cover sharp food items with a soft cushioning material, such as a paper towel, and reseal.
The FoodSaver® Fresh Container will not vacuum.	<ul style="list-style-type: none">• Make sure that the rubber gasket on the inside of the lid is free from food and secure in place.• Examine the rim of the container for cracks or scratches. Any gaps can prevent containers from vacuuming properly. Make sure that the container vacuum valve is clean.• Make sure that the container lid is closed securely on all 4 corners; remove lid and press again.
LED light on appliance blinks red.	<ul style="list-style-type: none">• This indicates that the appliance did not fully seal the container or bag. Raise the vacuum head and make sure that the container or bag is closed correctly.• Make sure that the liquid reservoir is clean and fitted correctly so there are no air leaks.• Move the vacuum head down and press it firmly onto the container or bag valve and press the Start button. The vacuum process should not take longer than 1 minute.
LED light on appliance blinks green.	<ul style="list-style-type: none">• This indicates that the container or bag valve is not attached to the vacuum head correctly. Move the vacuum head down and press it firmly onto the container or bag valve and press the Start button.

Guarantee

Please keep your receipt as this will be required for any claims under this guarantee.

This appliance is guaranteed for 2 years after your purchase as described in this document.

During this guaranteed period, if in the unlikely event the appliance no longer functions due to a design or manufacturing fault, please take it back to the place of purchase, with your till receipt and a copy of this guarantee.

The rights and benefits under this guarantee are additional to your statutory rights, which are not affected by this guarantee. Only Jarden Consumer Solutions (Europe) Limited ("JCS (Europe)") has the right to change these terms.

JCS (Europe) undertakes within the guarantee period to repair or replace the appliance, or any part of appliance found to be not working properly free of charge provided that:

- you promptly notify the place of purchase or JCS (Europe) of the problem; and
- the appliance has not been altered in any way or subjected to damage, misuse, abuse, repair or alteration by a person other than a person authorised by JCS (Europe).

Faults that occur through, improper use, damage, abuse, use with incorrect voltage, acts of nature, events beyond the control of JCS (Europe), repair or alteration by a person other than a person authorised by JCS (Europe) or failure to follow instructions for use are not covered by this guarantee. Additionally, normal wear and tear, including, but not limited to, minor discoloration and scratches are not covered by this guarantee.

The rights under this guarantee shall only apply to the original purchaser and shall not extend to commercial or communal use.

If your appliance includes a country-specific guarantee or warranty insert please refer to the terms and conditions of such guarantee or warranty in place of this guarantee or contact your local authorized dealer for more information.

Waste electrical products should not be disposed of with Household waste. Please recycle where facilities exist. E-mail us at enquiriesEurope@jardencs.com for further recycling and WEEE information.

Jarden Consumer Solutions (Europe) Limited
5400 Lakeside
Cheadle Royal Business Park
Cheadle
SK8 3GQ
United Kingdom

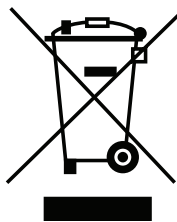

Installation of a Plug

If the plug is not suitable for the socket outlets in your home, it can be removed and replaced by a plug of the correct type. If you remove the plug it must not be connected to a 13 amp socket and the plug must be disposed of immediately.

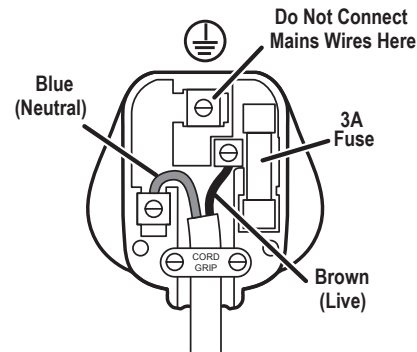

NOTE: If the terminals in the plug are not marked or if you are unsure or in doubt about the installation of the plug please contact a qualified electrician.

If a 13A 3-pin plug is fitted, it must be an ASTA approved plug, conforming to BS1363 standard. Replacement fuses must be BSI or ASTA BS1362 approved.

The wires in the mains lead are coloured as such:

- BROWN - LIVE
- BLUE - NEUTRAL

Please note that the colour of these mains wires may not correspond with the colour markings that identify the terminals in your plug.

The BROWN coloured wire must be connected to the terminal, which is marked with the letter "L" or is coloured RED.

The BLUE coloured wire must be connected to the terminal, which is marked with the letter "N" or is coloured BLACK.

DO NOT CONNECT either of these wires to the earth terminal in the plug. The earth terminal plug is marked with the letter "E", or with the earth symbol \perp , or coloured GREEN, or GREEN and YELLOW.



Jarden Consumer Solutions (Europe) Limited
Cheadle Royal Business Park, Cheadle, SK8 3GQ, United Kingdom
e-mail: enquiriesEurope@jardencs.com
Tel: 0161 621 6900



For Customer Service details, please see the website.

www.foodsaver.co.uk

© 2017 Jarden Consumer Solutions (Europe) Limited.

All rights reserved. Imported and distributed by Jarden Consumer Solutions (Europe) Limited, 5400 Lakeside, Cheadle Royal Business Park, Cheadle, SK8 3GQ, United Kingdom.

Jarden Consumer Solutions (Europe) Limited is a subsidiary of Newell Brands Inc. (NYSE: NWL).

The product supplied may differ slightly from the one illustrated due to continuing product development.

Printed In China